

ISL70417SEHEVAL1Z Evaluation Board User's Guide

Introduction

The ISL70417SEHEVAL1Z evaluation platform is designed to evaluate the ISL70417SEH. The ISL70417SEH contains four very high precision amplifiers featuring the perfect combination of low noise vs power consumption vs radiation hardness, providing highly reliable performance in harsh radiation environments. Its excellent noise characteristics coupled with an unique array of dynamic specifications make this amplifier well-suited for a variety of satellite system applications. Manufactured in Intersil's PR40, silicon on insulator, BiCMOS process makes this device immune to Single Event Latch-up.

Reference Documents

- ISL70417SEH Data Sheet; [FN7962](#)
- ISL70417SEH SMD [5962-12228](#)
- ISL70417SEH [Radiation Test Report](#)

Evaluation Board Key Features

- Dual Supply Operation: $\pm 4.5V$ to $\pm 20V$
- Singled-Ended or Differential Input Operation with Gain ($G = 10V/V$)
- External VREF Input
- Banana Jack Connectors for Power Supply and VREF Inputs
- BNC Connectors for Op Amp Input and Output Terminals
- Convenient PCB Pads for Op Amp Input/Output Impedance Loading

Power Supply Connections

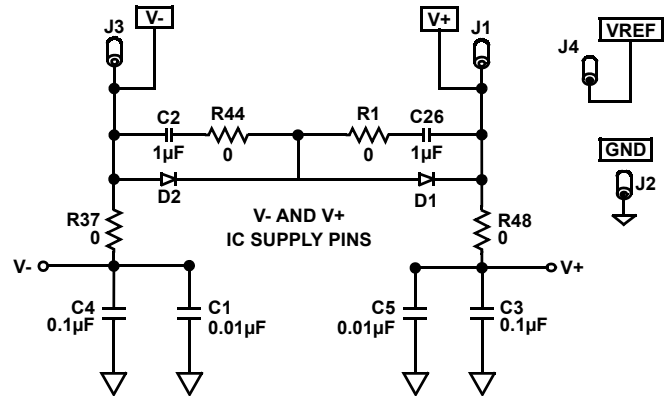

FIGURE 1. POWER SUPPLY CIRCUIT

Figure 1 demonstrates the power supply connections, decoupling and protection circuitry. External power connections are made through the V+, V-, VREF, and GND banana jack connections on the evaluation board. De-coupling capacitors C2 and C26 provide low-frequency power-supply filtering, while additional capacitors, C1, C3, C4 and C5 which are connected close to the part, filter out high frequency noise and are connected to their respective supplies through R37 and R48 resistors. These resistors are 0Ω but can be changed by the user to provide additional power supply filtering, or to reduce the supply voltage rate-of-rise time. Anti-reverse diodes D1 and D2 protect the circuit in the momentary case of accidentally reversing the power supplies to the evaluation board. The VREF pin can be connected to ground to establish a ground referenced input for split supply operation.

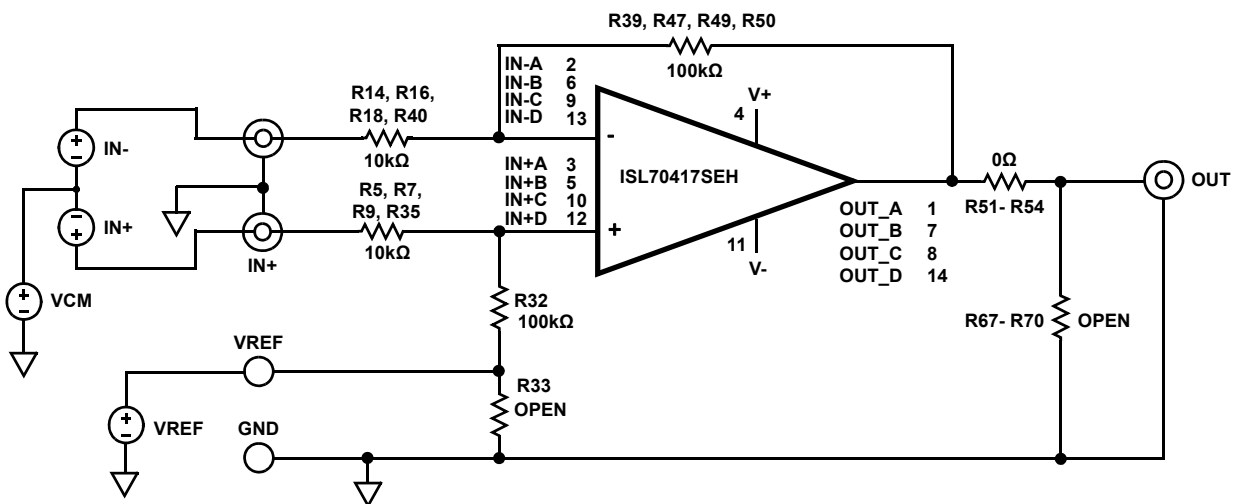

FIGURE 2. BASIC DIFFERENTIAL AMPLIFIER CONFIGURATION

Amplifier Configuration

A simplified schematic of the evaluation board is shown in Figure 2. The input stage with the components supplied is shown in Figure 3. The circuit implements a Hi-Z differential input with unbalanced common mode impedance. The differential amplifier gain is expressed in Equation 1:

$$V_{OUT} = (V_{IN+} - V_{IN-}) \cdot (R_F/R_{IN}) + V_{REF} \quad (EQ. 1)$$

For single-ended input with an inverting gain $G = -10V/V$, the IN+ input is grounded and the signal is supplied to the IN- input. VREF must be connected to a reference voltage between the V+ and V- supply rails. For non-inverting operation with $G = 11V/V$, the negative input (IN-) is grounded and the signal is supplied to the positive input (IN+). The non-inverting gain is strongly dependent on any resistance from IN- to GND. For good gain accuracy, a 0Ω resistor should be installed on the empty R11 pad.

User-selectable Options

Component pads are included to enable a variety of user-selectable circuits to be added to the amplifier inputs, the VREF input, outputs and the amplifier feedback loops.

A voltage divider can be added to establish a power supply-tracking common mode reference using the VREF input. The inverting and non-inverting inputs have additional resistor and capacitor placements for adding input attenuation or feedback capacitors (Figure 3).

The outputs (Figure 4) also have additional resistor and capacitor placements for filtering and loading.

NOTE: Operational amplifiers are sensitive to output capacitance and may oscillate. In the event of oscillation, reduce output capacitance by using shorter cables, or add a resistor in series with the output.

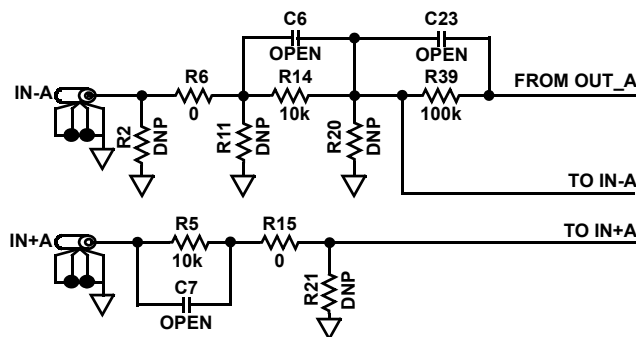

FIGURE 3. INPUT STAGE

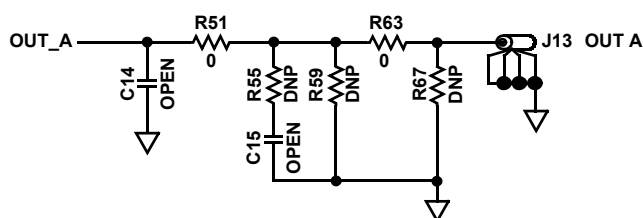
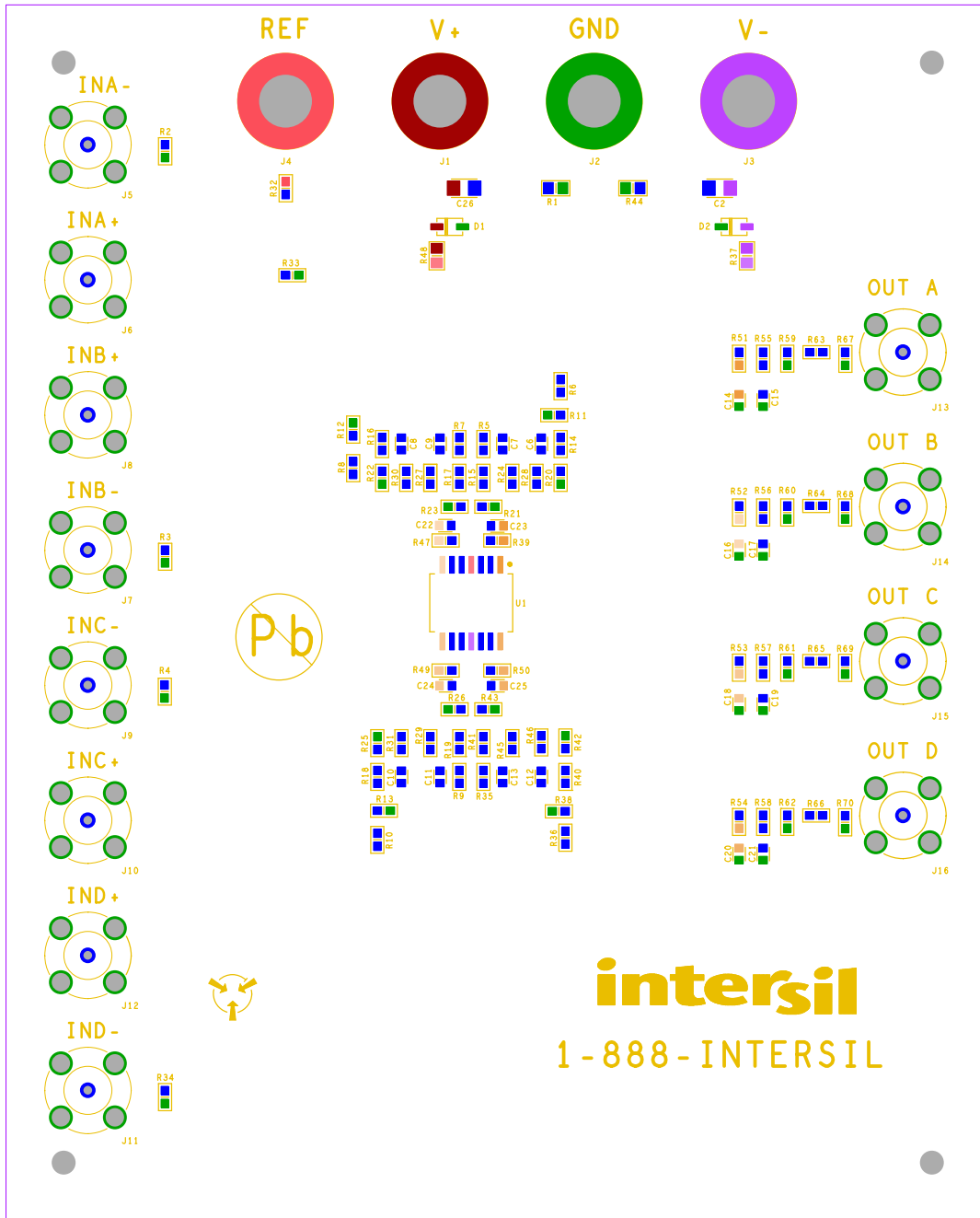

FIGURE 4. OUTPUT STAGE

TABLE 1. ISL70417SEHEVAL1Z COMPONENTS PARTS LIST

DEVICE #	DESCRIPTION	COMMENTS
C1, C5	CAP, SMD, 0805, 0.01μF, 50V, 10%, X7R, ROHS	Power Supply Decoupling
C2, C26	CAP, SMD, 1210, 1μF, 50V, 10%, X7R, ROHS	Power Supply Decoupling
C3, C4	CAP, SMD, 0805, 0.1μF, 25V, 10%, X7R, ROHS	Power Supply Decoupling
C6-C25	CAP, SMD, 0603, OPEN-PLACE HOLDER, ROHS	User selectable capacitors - not populated
D1, D2	40V SCHOTTKY BARRIER DIODE	Reverse Power Protection
J1-J4	Johnson Components Standard Type Banana Jack, 108-0740-001	Power Supply and Reference Voltage Connector
J5-J16	AMPHENOL BNC Connector, 31-5329-52RFX	Connections for Input and Output
R32	RESISTOR, SMD, 0603, 100kΩ, 1%, ROHS	VREF Resistor Divider
R5, R7, R9, R14, R16, R18, R35, R40	RESISTOR, SMD, 0603, 10kΩ, 1%, 1/16W, ROHS	Gain Setting Resistor
R39, R47, R49, R50	RESISTOR, SMD, 0603, 100kΩ, 1%, 1/16W, ROHS	Gain Setting Feedback Resistor
R2, R3, R4, R11, R12, R13, R20, R21, R22, R23, R25, R26, R28, R30, R31, R33, R34, R38, R42, R43, R46, R55, R56, R57, R58, R59, R60, R61, R62, R62, R67, R68, R69, R70	RESISTOR, SMD, 0603, DNP-PLACE HOLDER, ROHS	User selectable resistors - not populated
U1	ISL70417SEH, 40V RADIATION HARDENED, LOW NOISE QUAD OPERATIONAL AMPLIFIER	

ISL70417SEHEVAL1Z Top View



SILKSCREEN TOP

ISL70417SEHEVAL1Z Top Layer

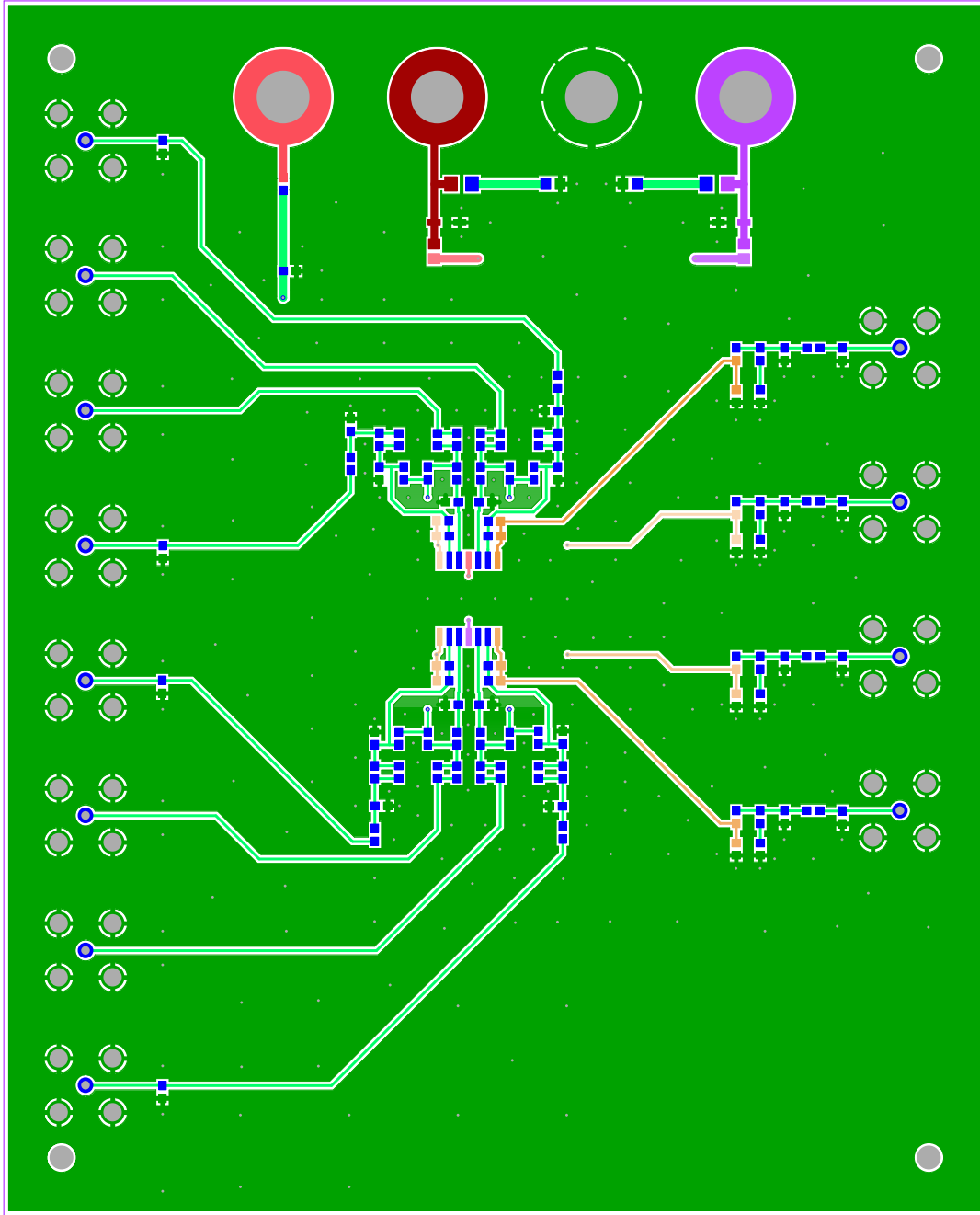

TOP LAYER

ISL70417SEHEVAL1Z Bottom Layer

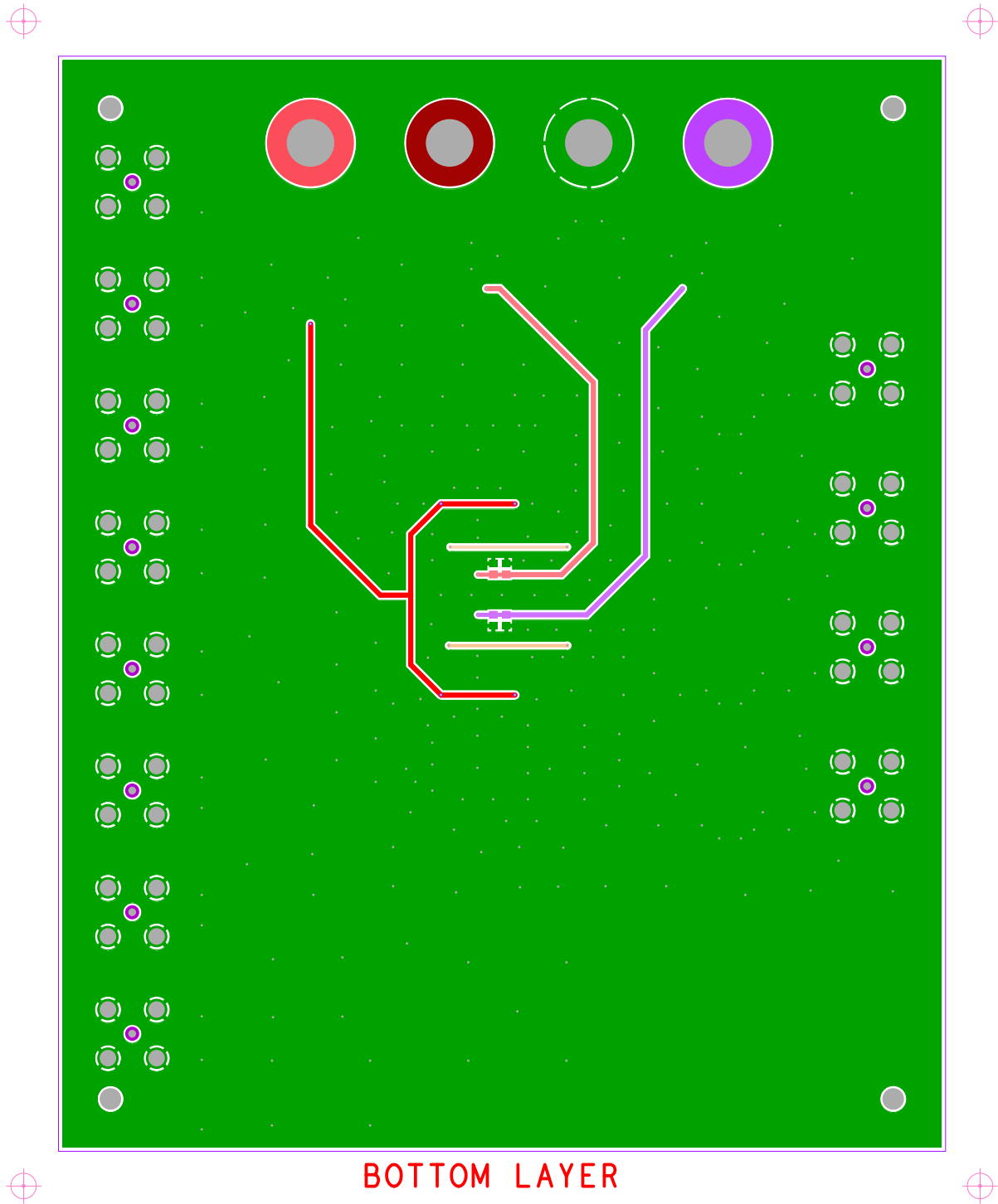

Intersil Corporation reserves the right to make changes in circuit design, software and/or specifications at any time without notice. Accordingly, the reader is cautioned to verify that the Application Note or Technical Brief is current before proceeding.

For information regarding Intersil Corporation and its products, see www.intersil.com

ISL70417SEHEVAL1Z Schematic Diagram

